

# Carbonylative Sonogashira Coupling of Terminal Alkynes with Aqueous Ammonia

Mohamed S. Mohamed Ahmed and Atsunori Mori\*

Chemical Resources Laboratory, Tokyo Institute of Technology, 4259 Nagatsuta,  
Yokohama 226-8503, Japan

amori@res.titech.ac.jp

Received June 5, 2003

## ABSTRACT

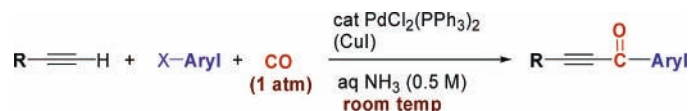

Carbonylative coupling of phenylethyne with 4-methoxy-1-iodobenzene in the presence of 1 mol % PdCl<sub>2</sub>(PPh<sub>3</sub>)<sub>2</sub>, 2 equiv of 0.5 M aqueous ammonia, and CO (1 atm) gives the corresponding α,β-alkynyl ketone in 72% isolated yield after stirring at room temperature for 41 h, while noncarbonylative coupling product is not obtained.

Synthesis of α,β-alkynyl ketones attracts considerable interest because of their appearance in a wide variety of biologically active molecules and their key synthetic intermediates.<sup>1</sup> A common route to prepare the compounds involves the reaction of alkynyl organometallic reagents such as silver,<sup>2</sup> copper,<sup>1,3</sup> sodium,<sup>4</sup> lithium,<sup>5</sup> cadmium,<sup>6</sup> zinc,<sup>7</sup> silicon,<sup>8</sup> and tin<sup>9</sup> with acid chlorides. An alternative synthetic method for α,β-alkynyl ketones is the transition metal-catalyzed coupling of terminal alkynes or the metalated derivatives with organic halides in the presence of carbon monoxide. Although the reaction of alkynylstannanes<sup>10</sup> or alkynylsilanes<sup>11</sup> is shown to proceed with carbon monoxide, little effort has been

directed for the reaction of terminal alkynes despite advantages in atom economy. Indeed, higher reaction temperature and pressure of carbon monoxide have been necessary in order to achieve the selective carbonylative coupling of terminal alkynes.<sup>12</sup> Only a few examples involving the reaction with fluoride ion in excess Et<sub>3</sub>N<sup>11</sup> or use of highly reactive iodonium salt as a substrate<sup>13</sup> are shown to proceed under mild conditions.

On the other hand, the Sonogashira–(Hagihara) reaction is recognized as a noncarbonylative coupling of terminal alkynes with organic halides and takes place in the presence of Pd(0)/Cu(I) catalyst.<sup>14</sup> The coupling reaction is a highly effective method for introducing an alkynyl moiety into an

(1) Chowdhury, C.; Kundu, N. G. *Tetrahedron* **1999**, *55*, 7011 and references therein.

(2) Davis, R. B.; Scheiber, D. H. *J. Am. Chem. Soc.* **1956**, *78*, 1675.

(3) (a) Normant, J. F. *Synthesis* **1972**, 63. (b) Logue, M. W.; Moore, G. L. *J. Org. Chem.* **1975**, *40*, 131. (c) Bourgain, M.; Normant, J. F. *Bull. Soc. Chim. Fr.* **1973**, 2137.

(4) Fontaine, M.; Chauvelier, J.; Barchewitz, P. *Bull. Soc. Chim. Fr.* **1962**, 2145.

(5) (a) Schmidt, U.; Schwochau, M. *Chem. Ber.* **1964**, *97*, 1649. (b) Compagnon, P. L.; Grosjean, B.; Lacour, M. *Bull. Soc. Chim. Fr.* **1975**, 779.

(6) Yashina, O. G.; Zarva, T. V.; Vereshchagin, L. I. *Zh. Org. Khim.* **1967**, *3*, 219; *Chem. Abstr.* **1967**, *66*, 94664g.

(7) Vereshchagin, L. I.; Yashina, O. G.; Zarva, T. V. *Zh. Org. Khim.* **1966**, *2*, 1895; *Chem. Abstr.* **1967**, *66*, 46070p.

(8) (a) Birkhofer, L.; Ritter, A.; Uhlenbrauck, H. *Chem. Ber.* **1963**, *96*, 3280. (b) Walton, D. R. M.; Waugh, F. J. *Organomet. Chem.* **1972**, *37*, 45.

(9) Logue, M. W.; Teng, K. *J. Org. Chem.* **1982**, *47*, 2549.

(10) (a) Goure, W. F.; Wright, M. E.; Davis, P. D.; Labadie, S. S.; Stille, J. K. *J. Am. Chem. Soc.* **1984**, *106*, 6417. (b) Grisp, G. T.; Scott, W. J.; Stille, J. K. *J. Am. Chem. Soc.* **1984**, *106*, 7500.

(11) Arcadi, A.; Cacchi, S.; Marinelli, F.; Pace, P.; Sanzi, G. *Synlett* **1995**, 823.

(12) (a) Kobayashi, T.; Tanaka, M. *J. Chem. Soc., Chem. Commun.* **1981**, 333. (b) Tanaka, M.; Kobayashi, T.; Sakakura, T. *Nippon Kagaku Kaishi* **1985**, 537; *Chem. Abstr.* **1986**, *104*, 129561d. (c) Delaude, L.; Masdeu, A. M.; Alper, H. *Synthesis* **1994**, 1149. (d) Fukuyama, T.; Yamaura, R.; Ryu, I. *Abstract 83rd Annual Meeting of Chemical Society of Japan, Tokyo, 2003*; 3G544.

(13) Luo, S. J.; Liang, Y. M.; Liu, C. M.; Ma, Y. X. *Synth. Commun.* **2001**, *31*, 343.

(14) (a) Sonogashira, K. In *Metal-Catalyzed Cross-Coupling Reaction*; Diederich, F., Stang, P. J., Eds.; Wiley-VCH: Weinheim, 1998; Chapter 5, pp 203–229. (b) Sonogashira, K.; Tohda, Y.; Hagihara, N. *Tetrahedron Lett.* **1975**, 4467. (c) Sonogashira, K. *J. Organomet. Chem.* **2002**, *653*, 46.

organic molecule; however, use of a large excess of amine as a solvent or a cosolvent has been key to the success of the reaction.<sup>15</sup> Hence, we have been studying effective activators<sup>16</sup> for the Sonogashira reaction instead of an excess use of amine of a high boiling point and found that use of dilute aqueous ammonia for the Sonogashira coupling was highly effective.<sup>17</sup>

Our interest has thus been turned to the reaction with aqueous ammonia for the carbonylative coupling of terminal alkynes. Herein, we report that palladium- or palladium/copper-catalyzed carbonylative coupling of terminal alkynes in aqueous ammonia proceeds *at room temperature and under an ambient pressure of carbon monoxide* to afford  $\alpha,\beta$ -alkynyl ketones efficiently.

The carbonylative reaction was first examined with Et<sub>3</sub>N as a solvent. However, treatment of phenylethyne (**1**) with 4-methoxy-1-iodobenzene (**2a**) in the presence of 1 mol % PdCl<sub>2</sub>(PPh<sub>3</sub>)<sub>2</sub> at room temperature under an ambient pressure of carbon monoxide resulted in giving the carbonylative coupling product **3a** in only 11% yield accompanied by 1% diarylethyne **4a**.<sup>12</sup> By contrast, when the reaction system was changed to that using 2 equiv of *aqueous ammonia* (0.5 M) in THF, remarkable rate enhancement and selective carbonylative coupling took place to afford 72% yield of **3a** as shown in Scheme 1. However, addition of a catalytic amount

**Scheme 1.** Coupling of Phenylethyne (**1**) with Aqueous Ammonia in the Presence of Carbon Monoxide

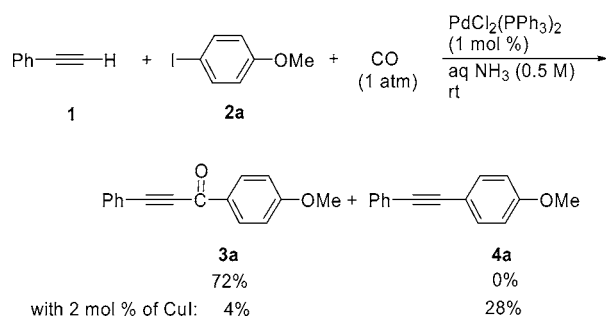

of CuI to the reaction system was found to be less effective in affording noncarbonylative coupling product **4a** as a major product.<sup>18</sup>

Table 1 summarizes the results for the carbonylative coupling of phenylethyne with various aryl iodides at room temperature under an ambient pressure of carbon monoxide. The reaction of 2-methoxy-1-iodobenzene (**2b**) and 3-methoxy-1-iodobenzene (**2c**) also proceeded with 1 mol % palladium catalyst in THF in the presence of 0.5 M aqueous ammonia (2 equiv) to yield 76 and 81% of the carbonylative coupling products, respectively. Use of 4-methyl-1-iodoben-

**Table 1.** Carbonylative Coupling of **1** with Aryl Iodides<sup>a</sup>

I-aryl	time, h	% yield	
		<b>3</b>	<b>4</b>
I-C <sub>6</sub> H <sub>4</sub> -4-OMe ( <b>2a</b> )	41	72	0
I-C <sub>6</sub> H <sub>4</sub> -2-OMe ( <b>2b</b> )	24	76	4
I-C <sub>6</sub> H <sub>4</sub> -3-OMe ( <b>2c</b> )	51	81	0
I-C <sub>6</sub> H <sub>4</sub> -4-Me ( <b>2d</b> )	47	64	0
I-C <sub>6</sub> H <sub>5</sub> ( <b>2e</b> )	25	76	0
1-iodonaphthalene ( <b>2f</b> )	34	50	1
I-C <sub>6</sub> H <sub>4</sub> -4-COMe <sup>b</sup> ( <b>2g</b> )	25 (61)	75 (53)	7 (23)
I-C <sub>6</sub> H <sub>4</sub> -4-Cl <sup>b</sup> ( <b>2i</b> )	12 (18)	67 (62)	0 (29)

<sup>a</sup> Reaction conditions: **1** (0.6 mmol), **2** (0.5 mmol), CO (1 atm), PdCl<sub>2</sub>(PPh<sub>3</sub>)<sub>2</sub> (1 mol %), aqueous ammonia (2 mL of 0.5 M solution), and THF (3 mL) at room temperature. <sup>b</sup> PdCl<sub>2</sub>(dppf) (5 mol %) was employed as a catalyst. The results using PdCl<sub>2</sub>(PPh<sub>3</sub>)<sub>2</sub> (1 mol %) are shown in parentheses.

zene (**2d**), iodobenzene (**2e**), and 1-iodonaphthalene (**2f**) resulted in giving the coupling products in good yields. Although the reaction with 4-iodoacetophenone (**2g**) or 4-iodo-1-chlorobenzene (**2i**), which possessed an electron-withdrawing substituent, afforded the mixture of carbonylative and noncarbonylative coupling products **3** and **4**, the selectivity to give **3** was remarkably improved when PdCl<sub>2</sub>(dppf) (5 mol %)<sup>12a,b</sup> was employed as a catalyst.

We next examined the carbonylative reaction of terminal alkynes bearing an alkyl substituent. The reaction was found to be slower than that of arylalkynes, whose relative reactivity was similar to the noncarbonylative coupling reactions. Considerably slower reaction of 1-octyne (**5a**) took place with 4-methoxy-1-iodobenzene (**2a**) to afford **6a** in 15% yield after stirring for 86 h under the conditions of Table 1. By contrast, addition of CuI to the reaction mixture was found to enhance the rate to yield the carbonylative coupling product **6a** in 65% yield. Use of 5 mol % PdCl<sub>2</sub>(PPh<sub>3</sub>)<sub>2</sub> with 2 mol % CuI further improved the yield of **6a** to 81% (Table 2).

The reaction of 1-octyne with 4-methyl-1-iodobenzene (**2d**) and 2-amino-1-iodobenzene (**2h**) also proceeded with 5 mol % palladium catalyst and 2 mol % CuI in THF in the presence of 0.5 M aqueous ammonia (2 equiv) to yield 78 and 71% of the carbonylative coupling products, respectively. The reaction of 1-iodonaphthalene also afforded the corresponding alkynyl ketone **6f**. The selectivity of carbonylative/noncarbonylative coupling of **5a** with aryl iodides bearing an electron-withdrawing group such as **2g** and **2i** was found to be better than that of phenylethyne (**1**). Other alkynes such as 3,3-dimethylbutyne (**5b**), 2-methyl-3-butyn-2-ol (**5c**), and 3-butyn-1-ol (**5d**) also coupled with **2** to afford the corresponding ynones in good to excellent yields, respectively.

(16) (a) Mori, A.; Kawashima, J.; Shimada, T.; Suguro, M.; Hirabayashi, K.; Nishihara, Y. *Org. Lett.* **2000**, 2, 2935. (b) Mori, A.; Shimada, T.; Kondo, T.; Sekiguchi, A. *Synlett* **2001**, 649. (c) Mori, A.; Kondo, T.; Kato, T.; Nishihara, Y. *Chem. Lett.* **2001**, 286.

(17) Mori, A.; Mohamed Ahmed, M. S.; Sekiguchi, A.; Masui, K.; Koike, T. *Chem. Lett.* **2002**, 756.

(18) Addition of 2 mol % CuI to the reaction system of standard Sonogashira conditions with CO also resulted in noncarbonylative coupling to yield 70% of **4a** and only 7% of **3a** after stirring at room temperature for 4 h.

(15) Recent studies on the improvement of Sonogashira coupling: (a) Herrmann, W. A.; Reisinger, C.-P.; Spiegler, M. *J. Organomet. Chem.* **1998**, 557, 93. (b) Böhm, V. P. W.; Herrmann, W. A. *Eur. J. Org. Chem.* **2000**, 3679. (c) Hundertmark, T.; Littke, A. F.; Buchwald, S. L.; Fu, G. C. *Org. Lett.* **2000**, 2, 1729. (d) Köllhofer, A.; Pullmann, T.; Plenio, H. *Angew. Chem., Int. Ed.* **2003**, 42, 1056. (e) Tykwinski, R. R. *Angew. Chem., Int. Ed.* **2003**, 42, 1566.

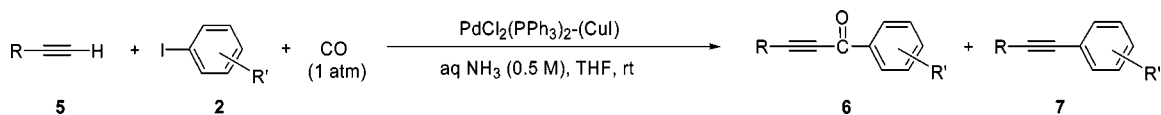
**Table 2.** Carbonylative Coupling of Alkynes Bearing an Alkyl Substituent

R-	I-aryl	PdCl <sub>2</sub> (PPh <sub>3</sub> ) <sub>2</sub> , mol%	CuI, mol %	time, h	product, % yield <sup>a</sup>		
					6	7	
<i>n</i> C <sub>6</sub> H <sub>13</sub> - ( <b>5a</b> )	I-C <sub>6</sub> H <sub>4</sub> -4-OMe ( <b>2a</b> )	1	0	86	15 <sup>b</sup>	0	
		1	2	48	65 <sup>b</sup>	0	
		5	2	24	74 (81) <sup>b</sup>	0	
	I-C <sub>6</sub> H <sub>4</sub> -4-Me ( <b>2d</b> )	5	2	24	78	0	
		I-C <sub>6</sub> H <sub>4</sub> -2-NH <sub>2</sub> ( <b>2h</b> )	5	2	40	71	0
		1-iodonaphthalene ( <b>2f</b> )	5	2	25	60	0
		I-C <sub>6</sub> H <sub>4</sub> -4-COMe ( <b>2g</b> )	5	2	30	47	5
		I-C <sub>6</sub> H <sub>4</sub> -4-Cl ( <b>2i</b> )	5	2	26	70	4
<i>t</i> Bu-( <b>5b</b> )	<b>2a</b>	5	4	27	53 ( <b>8</b> <sup>c</sup> ), 37 ( <b>9</b> <sup>c</sup> )	0 ( <b>10</b> <sup>d</sup> )	
		5	2	20	87	0	
		5	2	24	77	0	
HOC(CH <sub>3</sub> ) <sub>2</sub> -( <b>5c</b> )	<b>2a</b>	5	2	19	69	0	
		5	2	46	55 <sup>c</sup>	0	
HO(CH <sub>2</sub> ) <sub>2</sub> -( <b>5d</b> )	<b>2a</b>	5	2	48	56	0	

<sup>a</sup> Isolated yield, unless noted. <sup>b</sup> <sup>1</sup>H NMR yield. <sup>c</sup> **8**:

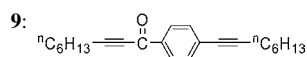
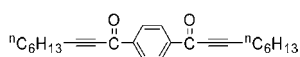

<sup>d</sup> **10**:

The reaction of 1-octyne with 1,4-diiodobenzene (**2j**) using PdCl<sub>2</sub>(PPh<sub>3</sub>)<sub>2</sub> (5 mol %) and CuI (4 mol %) in the presence of 0.5 M aqueous ammonia under an ambient pressure of carbon monoxide afforded dicarbonylated product **8** and monocarbonylated product **9** in 53 and 37% yields, respectively, after stirring at room temperature for 27 h. Since the product of the first coupling reaction is the electron-deficient aryl iodide, the second coupling would be less selective in accompanying noncarbonylative reaction, affording **9** with the carbonylation leading to **8**.

In general, a palladium-catalyzed reaction in the presence of carbon monoxide proceeds slower than that under an inert atmosphere since CO serves as a strong ligand with electron-withdrawing characteristics.<sup>12,19</sup> Nevertheless, it should be pointed out that the carbonylative reaction took place under ambient pressure and temperature. As shown in Scheme 2, the key for the understanding of selective carbonylative coupling would be the competition between transmetalation and CO insertion toward intermediate aryl palladium iodide species **I**, which is the resultant of the oxidative addition of an aryl iodide to Pd(0). Since the Sonogashira reaction (with Pd/Cu system) of a terminal alkyne bearing an aryl substituent is fast, transmetalation leading to **II** would be a preferable pathway to the insertion of CO. As a result, the noncarbonylative coupling would overcome the carbonylation when an aryl alkyne is employed as a substrate. By contrast, since the transmetalation of a terminal alkyne bearing alkyl

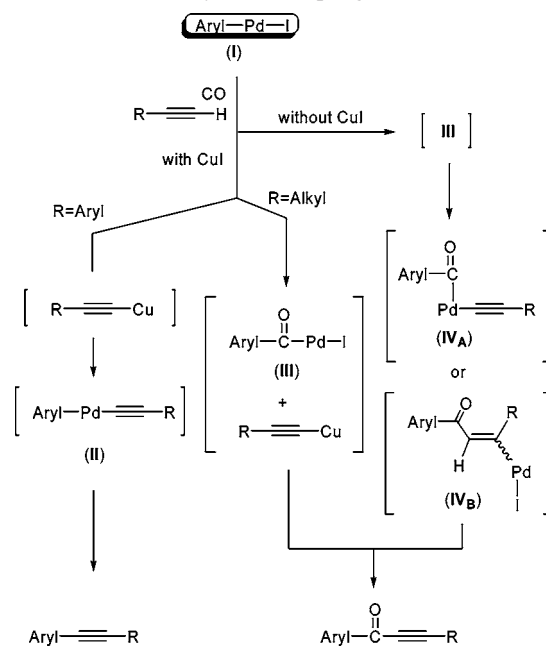
**Scheme 2.** Possible Explanation for Carbonylative/Noncarbonylative Coupling Reactions

substituent would be slower, insertion of CO leading to **III** is a major pathway even in the presence of CuI. Subsequent transmetalation from copper to palladium and reductive elimination afford the carbonylative coupling product. On

(19) Tsuji, J. In *Palladium Reagents and Catalysts. Innovation in Organic Synthesis*; Wiley: Chichester, 1995.

the other hand, in the reactions without CuI to result in the selective carbonylative coupling, the formation of **II** would be much slower than that of acylpalladium **III**. As a result, the selective carbonylative reaction is the major pathway throughout **IV<sub>A</sub>**. Alternatively, insertion of an arylalkyne to the acylpalladium species giving **IV<sub>B</sub>** followed by  $\beta$ -hydrogen elimination might be a plausible pathway.<sup>14</sup>

In conclusion, carbonylative coupling reaction of terminal alkynes with aryl halides catalyzed by palladium or a palladium/copper system took place at room temperature and under an ambient pressure of carbon monoxide. The reaction was found to proceed efficiently when dilute aqueous ammonia was used as an additive. The effect of aqueous ammonia is far superior to the use of an excess of tertiary amine as a solvent, under which conditions higher reaction temperature and CO pressure have to be applied to achieve the selective carbonylative reaction. As a result, the protocol using aqueous ammonia serves as a highly effective synthetic method for a variety of  $\alpha,\beta$ -alkynyl ketone derivatives.<sup>20</sup>

**Acknowledgment.** M.S.M.A. thanks Ministry of Education, Culture, Sports, Science, and Technology, Japan, for the financial support of graduate study program.

**Supporting Information Available:** Experimental details for the coupling reactions. This material is available free of charge via the Internet at <http://pubs.acs.org>.

OL035007A

---

(20) Typical preparation is as follows. To a clear pale yellow solution of phenylethyne (66  $\mu$ L, 0.6 mmol), 4-methoxy-1-iodobenzene (117 mg, 0.5 mmol), and PdCl<sub>2</sub>(PPh<sub>3</sub>)<sub>2</sub> (3.5 mg, 0.005 mmol) in THF (3 mL) was added aqueous ammonia (0.5 M, 2 mL, 1.0 mmol) dropwise. The atmosphere was replaced with carbon monoxide, and stirring was continued at room temperature for 41 h. The resulting mixture was passed through a Celite pad, and the filtrate was washed with brine. The aqueous layer was extracted with diethyl ether (3  $\times$  15 mL), and the combined organic layers were dried over MgSO<sub>4</sub> and concentrated in vacuo. The residue was purified by flash chromatography eluting with hexanes/ethyl acetate (10/1) to give 85 mg of 1-(4-methoxyphenyl)-3-phenyl-2-propynone (72%).